

SUBMITTAL

Ultra Low Pressure Transducer

PRODUCT SELECTION INFORMATION:

MODEL	Product Description
ULP	Jumper Selectable Ultra Low Pressure Transducer

CODE	Options
A	Standard
B	LCD Display

CODE	Range
01	0-1" W.C., ±1" W.C.
02	0-0.5" W.C., ±0.5" W.C.
03	0-0.25" W.C., ±0.25" W.C.
04	0-0.125" W.C., ±0.125" W.C.
05	0-250 Pa, ±250 Pa
06	0-125 Pa, ±125 Pa
07	0-60 Pa, ±60 Pa
08	0-30 Pa, ±30 Pa

CODE	Alarm Output
A	Alarm relay, N.O. 5 Amp

ULP	A	01	-
-----	---	----	---

Greystone Energy Systems, Inc. reserves the right to make design modifications without prior notice.

EXAMPLE: Ultra low pressure, ±1", 0-1" with alarm, No LCD

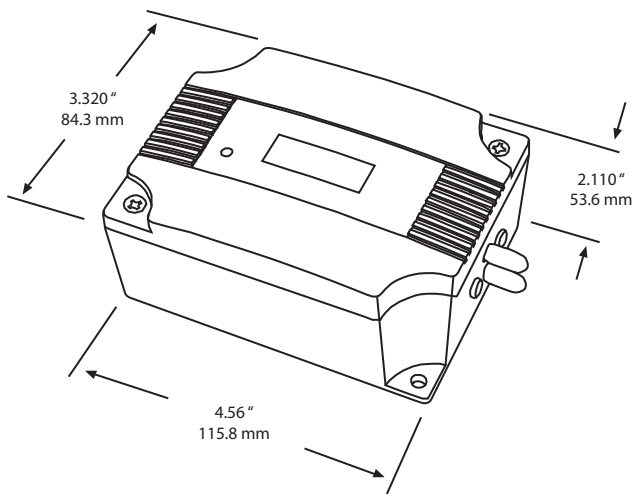

Part Number:

The ULP series is used to measure differential pressure between an area and a reference space. It combines precision high sensitivity silicon sensing capabilities and the latest in ASIC technology with Dynamic Self Compensation. Standard features include: Bi-directional pressure ranges, selectable output, and on-board auto-zeroing. A built-in alarm relay output and LCD are optional. Several accessories are available.

Accuracy	± 1% FSO
Measurement Type	Differential (two port)
Response Time	0.5 ms maximum
Over-pressure	100" W.C. (24.9 kPa)
Output Signal	4-20 mA (3-wire), 0-5 Vdc or 0-10 Vdc (3-wire) Pin jumper selectable
Power Supply	13-28 Vac, 18-35 Vdc (non-isolated half-wave rectified)
Power Consumption	<4 mA <50 mA - with Alarm option
Zero Adjustment	Pushbutton auto-zero (on device or remote)
Wiring	Screw terminal block (14 - 22 AWG)
Pressure Connection	Barbed ports for 0.17" (4.3 mm) ID flexible tubing
Display	3½ digit LCD, 0.4" (10 mm) digit height
Relay Output	N.O. contact, 2.5 amps @ 120 Vac, 2.5 amps @ 30 Vdc
Relay Trip Point	Adjustable from Zero to Span via trimpot
Relay delay	5 seconds on / 5 seconds off

Installation:

For complete installation and wiring details, please refer to the product installation instructions.

The ULP mounts on any surface using the two holes provided on the base of the unit. Make sure there is enough space around the unit to connect the pressure tubing without kinking and avoid locations where severe vibrations or excessive moisture are present.

The unit may be mounted in any position but typically is installed on a vertical surface with pressure ports on the right and the cable entrance on the left. The enclosure has a standard opening for a 1/2" conduit and may be installed with either conduit and a conduit coupler or a cable gland type fitting.



GREYSTONE

ACCURACY BY DESIGN

Greystone Energy Systems, Inc.
150 English Drive, Moncton, NB
Canada E1E 4G7

(506) 853-3057 Fax: (506) 853-6014
North America: 1-800-561-5611
e-mail: mail@greystoneenergy.com
www.greystoneenergy.com

RoHS
COMPLIANT



Typical Installation

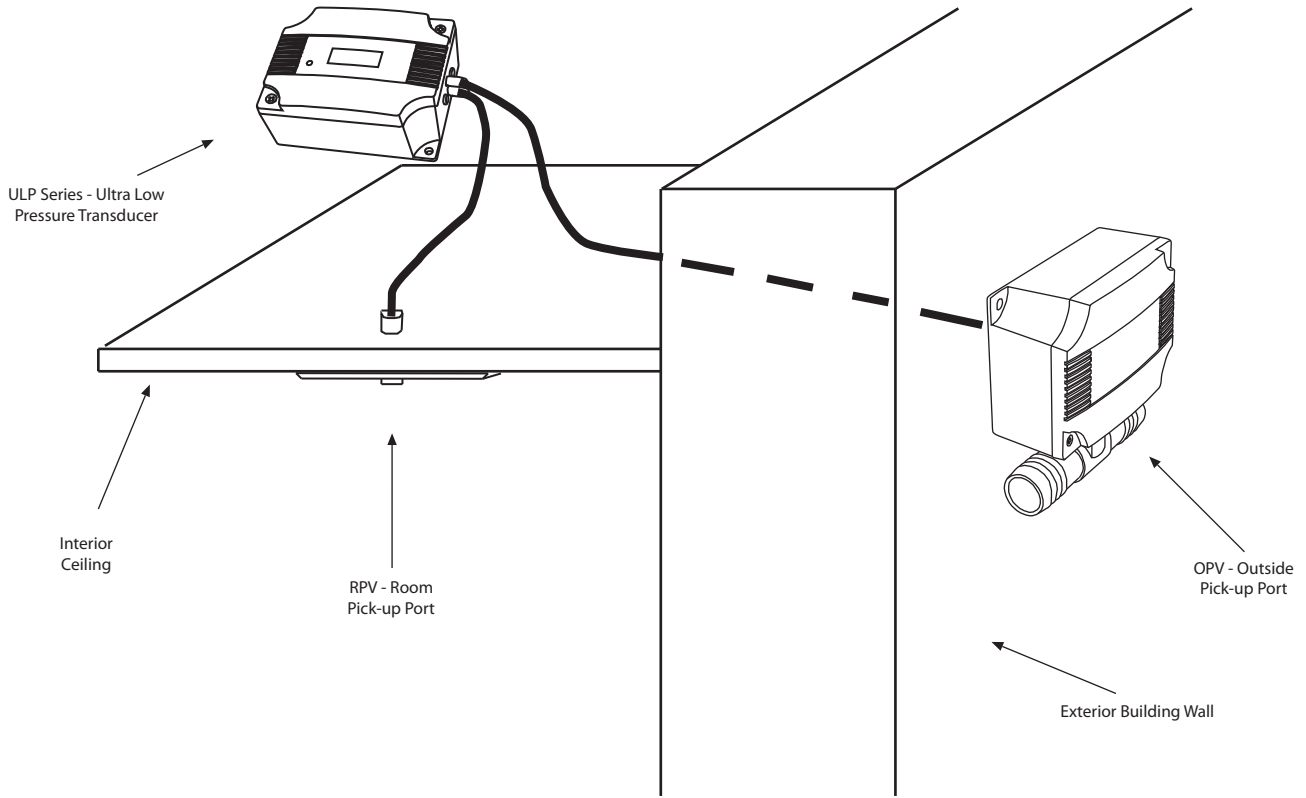

Accessories

RPV - Stainless Plate Pick-up Port

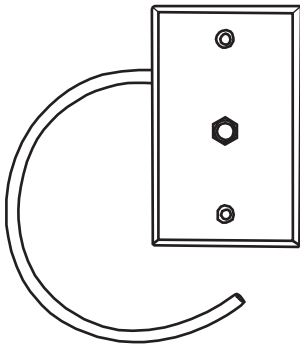

EPV - ABS Executive Pick-up Port

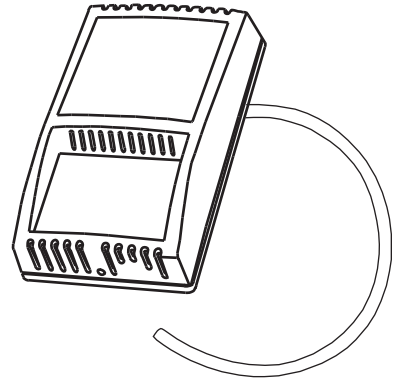

OPV - Outside Pick-up Port

