

SUBMITTAL

Duct Humidity Transducer

Part Number:

PRODUCT SELECTION INFORMATION:

MODEL	Product Description
RH200	Duct Humidity Transducer

CODE	Enclosure
A	ABS enclosure, standard
M	Metal utility box
E	Round ABS, w/gasketed cover
W	Aluminum weatherproof box

CODE	Accuracy
02	2%
03	3%
05	5%

CODE	Optional Temperature Sensor
L	PT100-100 Ω Plat. IEC 751, 385 Alpha, thin film
C	PT1000-1000 Ω Platinum, IEC 751, 385 Alpha, thin film
F	1801 Ω, NTC Thermistor, ±0.2 C
E	3000 Ω, NTC Thermistor, ±0.2 C
H	100,000 Ω, NTC Thermistor, ±0.2 C
D	10,000 Ω, Type 3, NTC Thermistor, ±0.2 C
J	10,000 Ω, Type 2, NTC Thermistor, ±0.2 C
K	20,000 Ω, NTC Thermistor, ±0.2 C
M	1000 Ω Nickel
B	10,000 Ω, Type 3, NTC Thermistor, ±0.2 C c/w 11K shunt resistor
G	2,252K Ω, NTC Thermistor, ±0.2 C

CODE	Options
AC	LCD display (ABS Enclosure only)

RH200 A 02 K -

Greystone Energy Systems, Inc. reserves the right to make design modifications without prior notice.

EXAMPLE: Duct humidity, ABS Enclosure, 2% c/w 20 K Thermistor

LCD Specifications:

Display Units % RH (Factory set)
 Display Range 0 – 99.9%
 Display Resolution 0.5% for display of 00.0 to 99.9
 Display Update Rate 3 times per second
 Display Size 24 mm W x 11 mm H (0.95" x 0.45") three digit

The RH200 series uses a highly accurate and reliable Thermoset Polymer based capacitance humidity sensor and state-of-the-art digital linearization and temperature compensated circuitry to monitor humidity levels. The sensor is encapsulated in a 9" (228.60 mm) long by 0.5" (12.7 mm) diameter 304 S/S probe. An 60 micron HDPE filter protects the sensor for contaminants. A variety of enclosures are available. Additional options such as integrated temperature sensor and LCD display are available.

Sensor Type	Thermoset Polymer based capacitive
Range	0 to 100% RH
Accuracy	±2, 3, or 5 % (5 to 95% RH)
Response	15 Seconds typical
Stability	±1% RH typical @ 50% RH in 5 years
Operating Temperature	-40 to 70 °C (-40 to 158 °F)
Power Supply	18 to 30 Vdc, 15 to 26 Vac
Output Signal	Jumper-selectable 4-20 mA current loop 0-1, 0-5, or 0-10 Vdc
Consumption	22 mA maximum
Enclosure	Standard - ABS - UL94-V - NEMA 1 (IP10) Round (E) - ABS - NEMA 4X (IP56) Metal (M) - Galvanized Steel - NEMA 1 (IP10) Weatherproof (W) - Cast Aluminum - NEMA 3R (IP14)
Probe	304 series stainless steel w/ 60 micron HDPE filter
Optional Temperature Sensor	Various RTD's and thermistors available as 2 wire resistance outputs (See ordering chart)
Wiring Connections	Screw terminal block (14 to 22 AWG)

Installation:

The duct type probes are installed through a hole in the side of the duct to monitor a single point humidity within the duct. Install the probe in a straight section of duct at a suitable distance downstream from any heating, cooling or humidification devices.

Each enclosure style provides mounting tabs on the outside of the enclosure for ease of installation .

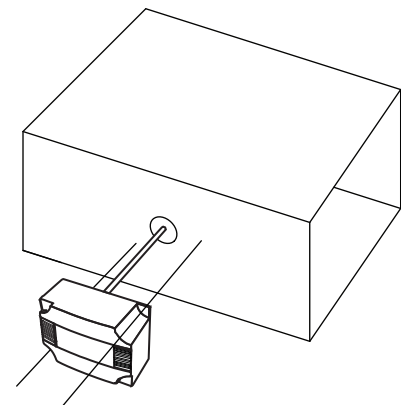

GREYSTONE

ACCURACY BY DESIGN

Greystone Energy Systems, Inc.
 150 English Drive, Moncton, NB
 Canada E1E 4G7

(506) 853-3057 Fax: (506) 853-6014
 North America: 1-800-561-5611
 e-mail: mail@greystoneenergy.com
 www.greystoneenergy.com

RoHS
 COMPLIANT



Dimensions:



GREYSTONE
ACCURACY BY DESIGN

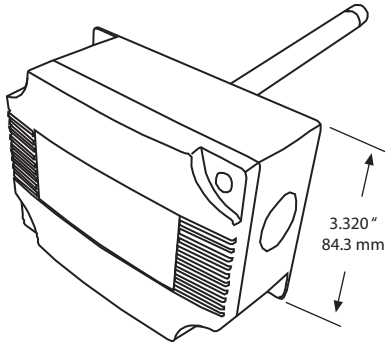

ABS Enclosure

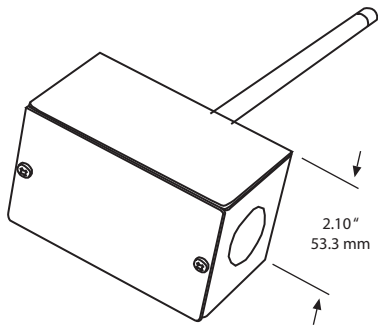
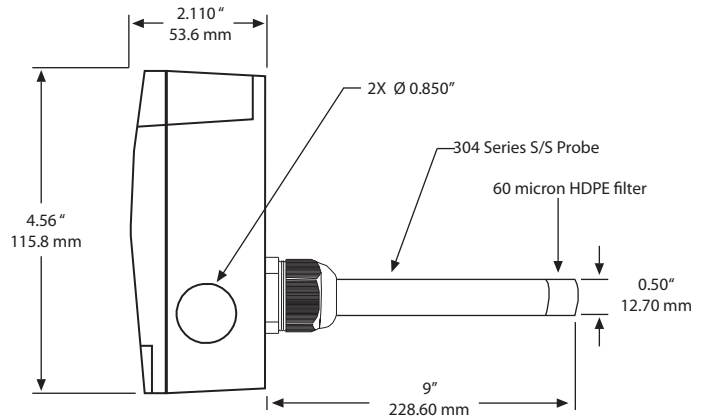

Metal Enclosure (M)

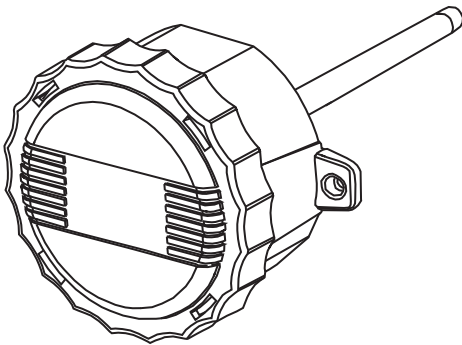
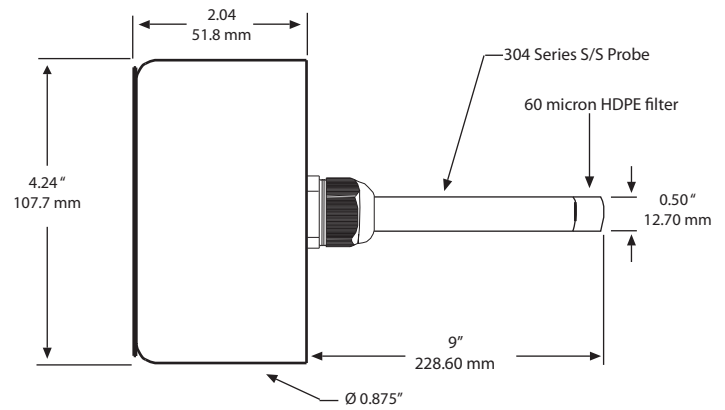

Round ABS Enclosure (E)

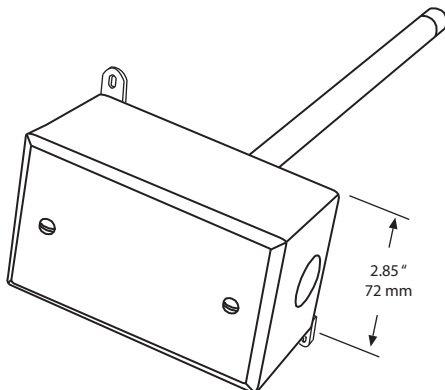
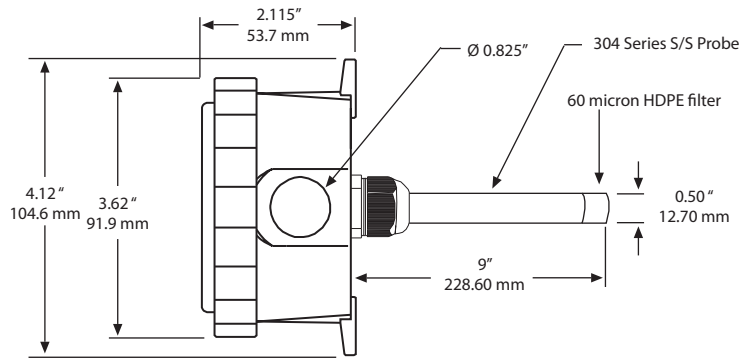

Weatherproof Enclosure (W)

